

WHAT'S INCLUDED IN THE BOX:

- 1x Diffuser hose Bubble Tubing® (Option of 25 ft, 50 ft or 100 ft)
- 1x Check Valve
- 2x Clamps
- 1x Plug
- 1x Adapter 3/8"
- 1x Adapter 1/2"



BUBBLE TUBING® PREPARATION

Before connecting Bubble Tubing® to the feeder line, unroll it, making sure it is not twisted. Tubing well straighten allows a uniform dispersion of air through all its length. By unrolling the tubing length before installing them, you improve efficiency of the system and affect life of the compressor. Let the tubing rest in the sun unrolled before the installation of the system. *Connect the check valve and the plug at each end of the diffuser while unrolled. It will make an easier connection with the feeder lines later on.*

ASSEMBLY INSTRUCTIONS

The following assembly instructions will help you make the connections between the Torpedo air supply hose and Bubble Tubing® diffuser. Use the hardware and fittings provided for a leak-free connection.

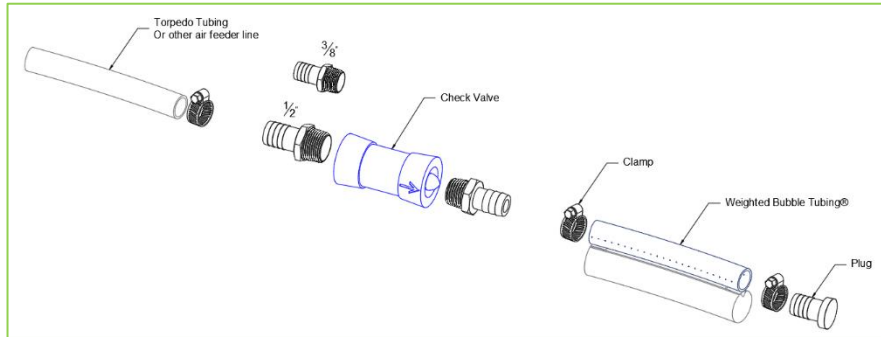

- Before getting to the tubing connection, make sure you choose the right adapter for your feeder line, either the 3/8" adapter or the 1/2" adapter, both included in the box.
- Screw the chosen adapter onto the check valve

TUBING CONNECTION - STEP 1

Hold the unconnected end of the air hose (the other end should already be connected to the heat-resistant hose or feeder) and the check valve. Insert a non-tightened collar on the unconnected end of the feeder line, inserting the hose over the barbed section on the correct side of the check valve. Make sure the air flow follows the directional arrow on the valve (see black arrows in photo below) and tighten the collar around the air hose using a flat-head screwdriver.

Connect the hose (at the right of the valve in this case). The air flow must follow the direction of the black arrow towards the diffuser hose.



Expected result by following the steps on the next page

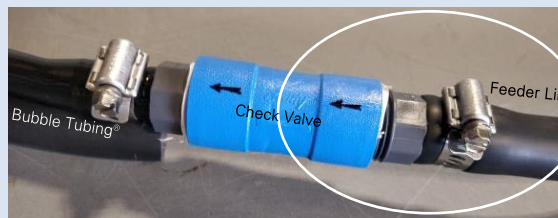

TUBING CONNECTION - STEP 2

To make connections with Bubble Tubing®, follow the steps below. We have also made an explanatory video. Link: [Click here](#) or scan the QR code with your smart phone. *If requested in advance, the Bubble Tubing can already be connected to the check valve (assembly cost may apply).*



- 1- With a knife, cut 1 inch deep between the ballast and the diffuser tubing on both ends of the Bubble Tubing®. Make sure not to cut the air tube (shallow part).
- 2- Insert a loosen clamp to one end of the Bubble Tubing® diffuser, insert the tubing over the remaining barbed portion of the check valve and tighten the clamp around the Bubble Tubing® using a flathead screwdriver.



- 3- Take the other end of the Bubble Tubing® which has already been cut in point 1 above. Insert a loosen clamp over the tubing, insert the tubing over the barbed portion of the plug and tighten the clamp around the Bubble Tubing® using a flathead screwdriver.
- 4- The picture below is a zoom of the result you should expect when the plug installation is complete:



For instructions on how to install your diffuser in the water. Scan the first QR code if you're using your Bubble Tubing® for aeration (Canadian Air). Scan the second QR code if you are using your Bubble Tubing® for deicing (Thawline).



Canadian Air
Aeration System



Thawline
Systems

MAINTENANCE

Bubble Tubing® is designed to permanently stay at the bottom of water. Various conditions (biofilm, calcification, etc.) can reduce aeration performance with time (less bubbles visible at the surface). In this case, cleaning the tubing might be needed. For optimal performance, we recommend cleaning the tubing once or twice a year, based on water quality. BioPurge and EcoPurge are the only products tested and approved to clean the Bubble Tubing. Do not use chlorine, Javex, Drano or any other chemical product to clean the tubing. Do not use a compressor providing more than 50 PSI or a shop compressor not equipped with a pressure regulator.

WARRANTY

CanadianPond.ca Products Ltd. offers a 5 years warranty on Bubble Tubing®.

Warranty Claim Procedure

Be sure to have the original purchase invoice on hand before contacting us for a claim. Contact Canadianpond.ca Products Ltd. at 450-243-0976 or by email info@canadianpond.ca. No returns will be accepted without a return authorization number provided by Canadian Pond.ca Products Ltd.

Terms and Conditions

Any questions regarding your purchase, please refer to the terms and conditions by scanning this QR Code.



Terms and
Conditions