

## DIAPHRAGM ELECTRIC AIR COMPRESSOR

- Oil-less operation
- Permanently lubricated bearings
- Field service capability
- Stainless steel valves and aluminium valve plate
- Lightweight die cast aluminium head and diaphragm hold down plate
- Long-life diaphragm
- Inlet filter
- Balanced for smooth, low vibration operation
- 6 ft. grounded cord and plug
- 115-volt UL recognised motor and thermal protector
- CE Approved 220-volt, 50-hertz model.
- Service Kit SK927

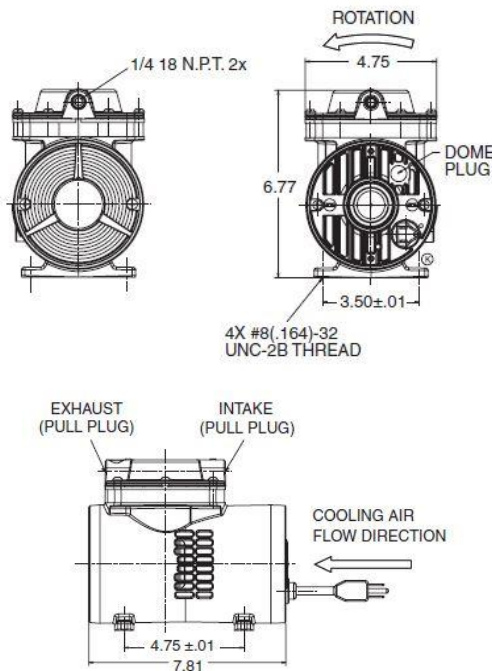

<b>MODEL NUMBER</b>		<b>927CA18</b>	
<b>HEAD CONFIGURATION</b>		Pressure/Vacuum	
<b>STROKE</b>		.180 Inches	
<b>PRESSURE</b>		Flow @ 115v	
CFM @ PSI	LPM @ bar		
PSI	bar	CFM	LPM
0	0	1.24	35.1
5	.5	1.11	29.5
10	1.0	.96	23.4
15	1.5	.81	17.1
20	2.0	.65	12.9
25	3.0	.52	4.6
30	5.0	.44	
35	7.0	.35	
40	10.0	.24	
<b>MAX. CONTINUOUS PRESSURE</b>		30 PSI	2.1 bar
<b>MAX. INTERMITTENT PRESSURE</b>		40 PSI	2.8 bar
<b>VACUUM</b>		Flow @ 115v	
CFM @ IN. hg	LPM @ mbar (gauge)		
IN. hg	mbar (gauge)	CFM	LPM
0	0	1.24	35.1
5	-100	.89	29.3
10	-200	.64	23.9
15	-400	.36	15.2
20	-600	.16	7.1
<b>MAX. VACUUM</b>		23.8* hg	-807 mbar
<b>MAX. AMBIENT AIR TEMP.</b>		104° F	40°C
<b>MIN. AMBIENT START TEMP.</b>		50° F	10°C
<b>MAX. RESTART PRESSURE</b>		0 PSI	0 bar
<b>MAX. RESTART VACUUM</b>		0*hg	0mbar
<b>MOTOR VOLTAGE/FREQUENCY</b>		115/60/1	
<b>MOTOR TYPE</b>		Shaded Pole	
<b>CURRENT AT RATED LOAD (AMPS)</b>		3.00	
<b>POWER AT RATED LOAD (WATTS)</b>		191	
<b>STARTING CURRENT (LOCKED ROTOR, AMPS)</b>		5.5	
<b>MIN. FULL LOAD SPEED (RPM)</b>		1625	
<b>THERMAL PROTECTOR</b>		Yes	